

Product Highlights

In-Vehicle Mobile Broadband

4G/LTE mobile connectivity lets you deploy a mobile broadband connection in a moving vehicle

High-speed Connectivity

Enjoy high-speed wireless IEEE 802.11 ac with speeds of up to 866 Mbps, allowing for quick Internet access and data transfer

Enterprise Class VPN options

A variety of powerful, yet easy to set up VPN tools give you flexibility in deployment and management



DWM-321

4G LTE In-Vehicle Hotspot

Features

Connectivity

- WAN port to connect to the Internet
- Three 10/100/1000 Ethernet LAN ports to connect wired devices for high-speed activities
- SIM card slot for a mobile broadband connection
- Wireless 802.11ac/n/g/b/a

Security Features

- Supports WPA, WPA2, WPA-PSK, WPA2-PSK, and 802.1x encryption
- Dual-active firewalls (NAT/SPI) to control traffic and help resist attacks over the Internet

Advanced VPN Features

- Supports VPN tunnels for IPSec, OpenVPN, L2TP (over IPSec), PPTP, and GRE
- VPN Scenarios: Site to Site, Site to Host, Host to Site, Host to Host
- IPSec NAT-Traversal

Rugged and Flexible

- Zinc-plated steel case for durability
- Wide operating temperature and humidity tolerance
- Wall mounting for optimal placement

The D-Link DWM-321 4G LTE In-Vehicle Hotspot is an easy-to-deploy high-performance router with mobile connectivity to allow easy access to mobile broadband networks. It's the easiest way to deploy an in-vehicle concurrent dual band hotspot gateway, providing passengers with Wi-Fi access in a moving vehicle such as public transport services.

Connectivity On the Go

The DWM-321 acts as a hotspot gateway to let passengers in a vehicle connect to a 4G/LTE mobile connection, with fast downlink speeds of up to 150 Mbps, and uplink speeds of up to 50 Mbps. Deploy it in a moving vehicle to give passengers fast, responsive Internet access on the go. The blazing fast LTE connection allows multiple users to access e-mail and stream music and video all at the same time. Configurable dual-SIM fallback provides reliability and flexibility in mixed network environments.

Reliable Virtual Private Networks

The DWM-321 4G LTE In-Vehicle Hotspot lets you create a high-speed Virtual Private Network (VPN) for access remotely or locally. It supports different tunneling technologies to establish tunnels between multiple sites for data transferring, such as IPSec, OpenVPN, L2TP (over IPSec), PPTP, and GRE. Advanced functions such as full tunnel, tunnel failover, tunnel load balance, NetBIOS over IPSec, NAT Traversal, and Dynamic VPN are also supported. With the DWM-321 you'll have all the tools you need to create the ideal VPN solution for your network.

Robust

The industrial-grade casing means the DWM-321 provides reliable high-speed connectivity in extreme conditions. The corrosion-resistant zinc-plated steel case, wide operating temperature and humidity tolerance mean that the DWM-321 is ready for the most demanding M2M applications in virtually any environment. Wall mounts allow the DWM-321 to be mounted virtually anywhere for optimal connectivity.

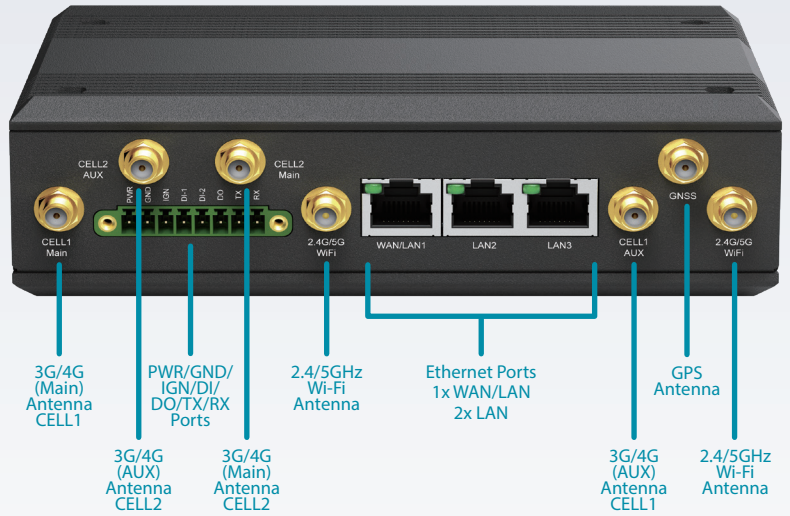
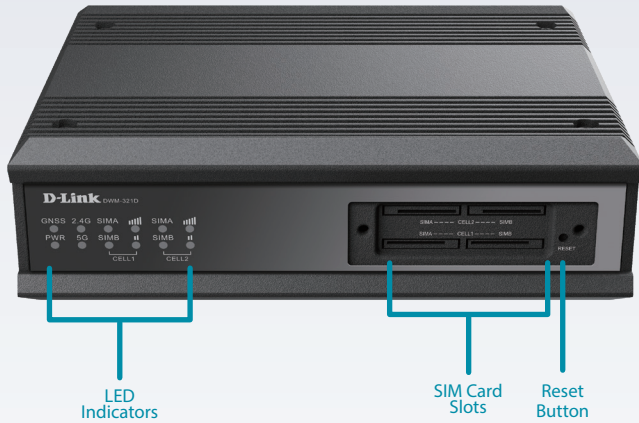

Example Network

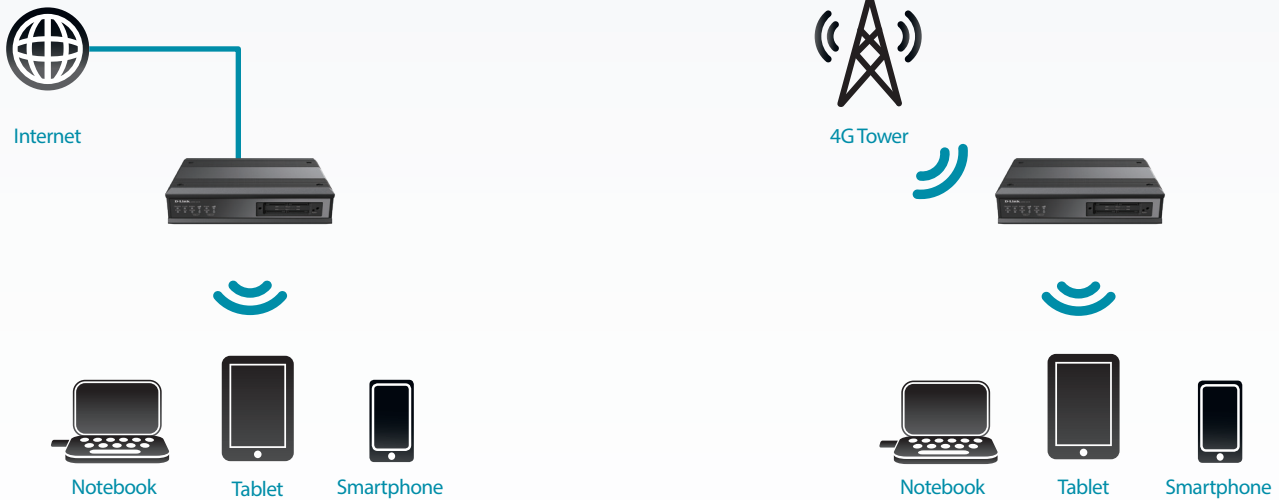

Technical Specifications

General

Cellular Frequency Support ¹

- SKU 1
 - LTE Cat. 4 Bands 1/3/5/7/8/20/38/40/41
 - UMTS/HSPA B1/B5/B8, 850/900/2100 MHz
 - GSM/GPRS/EDGE: 900/1800 MHz
- SKU 2
 - LTE Cat. 4 Bands 2/4/12
 - UMTS/HSPA B2/B4/B5, 850/1700/1900 MHz
- SKU 3
 - LTE Cat 4 Bands 4/13
- SKU 4
 - LTE Cat. 4 Bands 1/2/3/4/5/7/8/28/40
 - UMTS/HSPA B1/B2/B5/B8, 850/900/1900/2100 MHz
 - GSM/GPRS/EDGE: 850/900/1800/1900 MHz
- SKU 5
 - LTE Cat. 4 Bands 1/3/8/18/19/26/41
 - UMTS/HSPA B1/B6/B8/B19, 800/900/2100 MHz
- SKU 6
 - LTE Cat. 4 Bands 1/3/7/8/20/28A/38/40/41
 - UMTS/HSPA B1/B8, 900/2100 MHz
 - GSM/GPRS/EDGE 900/1800 MHz
- SKU-A
 - Four LTE external antennas
 - Four SIM slots
- SKU-B
 - Two LTE external antennas
 - Two SIM slots

Maximum Cellular Data Throughput

- LTE FDD: 150 Mbps (DL) / 50 Mbps (UL)
- LTE TDD: 130 Mbps (DL) / 30 Mbps (UL)
- DC-HSDPA/HSUPA: 42 Mbps (DL) / 5.76 Mbps (UL)
- WCDMA: 384 Kbps (DL) / 384 Kbps (UL)
- EDGE: 296 Kbps (DL) / 236.8 Kbps (UL)
- GPRS: 107 Kbps (DL) / 85.6 Kbps (UL)

DWM-321 4G LTE In-Vehicle Hotspot

Device Interfaces	<ul style="list-style-type: none"> • One 10/100/1000 Ethernet WAN/LAN port • Two 10/100/1000 Ethernet LAN ports • DI/DO/TX/RX/Grounding ports 	<ul style="list-style-type: none"> • One DC power input • Four SIM slots (Two are optional) • IGN (Ignition Sense) Power Control function
Antennas	<ul style="list-style-type: none"> • Four LTE external antennas (Two are optional) 	<ul style="list-style-type: none"> • Two Wi-Fi antennas
Standards	<ul style="list-style-type: none"> • IEEE 802.11ac/n/g/b/a 	
Wi-Fi Data Rates ²	<ul style="list-style-type: none"> • Up to 866 Mbps with 802.11ac clients • Up to 300 Mbps with 802.11n clients 	<ul style="list-style-type: none"> • 6/9/11/12/18/24/36/48/54 Mbps in 802.11g mode • 1/2/5.5/11 Mbps in 802.11b mode
Functionality		
Wireless Security Features	<ul style="list-style-type: none"> • WPA/WPA2/WPA-PSK/WPA2-PSK/802.1x encryption 	
Firewall	<ul style="list-style-type: none"> • Network Address Translation (NAT) • Stateful Packet Inspection Firewall with Stealth Mode • IPS Access Control: Packet Filters • Application Filter 	<ul style="list-style-type: none"> • URL Blocking • MAC Address Control • Content Filter
Advanced Features	<ul style="list-style-type: none"> • QoS engine (Quality of Service) • SNMP Support • Port Forwarding • Virtual Server 	<ul style="list-style-type: none"> • Web-based UI • TR-069 CPE WAN Management Protocol • DMZ & Pass Through
VPN	<ul style="list-style-type: none"> • L2TP/OpenVPN/PPTP/IPSEC/GRE VPN 	
Physical		
Power	<ul style="list-style-type: none"> • DC 9V / 2.7 A ~ 36 V / 0.7 A 	
Dimensions	<ul style="list-style-type: none"> • 160 x 125 x 47 mm (6.30 x 4.92 x 1.85 in) 	
Weight	<ul style="list-style-type: none"> • 865 g (1.9 lbs) 	
Temperature	<ul style="list-style-type: none"> • Operating: -30 to 60 °C (-22 to 158 °F) 	<ul style="list-style-type: none"> • Storage: -40 to 85 °C (-40 to 185 °F)
Humidity	<ul style="list-style-type: none"> • Operating: 10% to 95% non-condensing 	<ul style="list-style-type: none"> • Storage: 0 to 95% non-condensing
Certifications	<ul style="list-style-type: none"> • CE 	<ul style="list-style-type: none"> • EAC
Order Information		
<i>Part Number</i>	<i>Description</i>	
DWM-321	4G LTE In-Vehicle Hotspot	

¹ Supported frequency band is dependent upon hardware SKU.

² Data rates are theoretical. Data transfer rate depends on network capacity and signal strength, and environmental factors.

Updated 2019/05/29